

**PROFESSIONAL SERIES
BUILT-IN GAS COOKTOP WARRANTY**

ONE YEAR FULL WARRANTY

Built-in gas cooktops (VGSU Series) and all of their component parts, except as detailed below, are warranted to be free from defective materials or workmanship in normal household use for a period of twelve (12) months from the date of original retail purchase. Viking Range Corporation, warrantor, agrees to repair or replace, at its option, any part which fails or is found to be defective during the warranty period.

*Painted, porcelain and decorative items are warranted to be free from defective materials or workmanship for a period of ninety (90) days from the date of original retail purchase. ANY DEFECTS MUST BE REPORTED TO THE SELLING DEALER WITHIN NINETY (90) DAYS FROM DATE OF ORIGINAL RETAIL PURCHASE.

Viking Range Corporation uses the most up-to-date processes and best materials available to produce all color finishes. However, slight color variation may be noticed because of the inherent differences in painted parts and porcelain parts as well as differences in kitchen lighting, product locations, and other factors.

FIVE YEAR LIMITED WARRANTY

Any surface burner which fails due to defective materials or workmanship in normal household use during the second through fifth year from the date of original retail purchase will be repaired or replaced, free of charge for the part itself, with the owner paying all other costs, including labor.

This warranty shall apply to products purchased and located in the United States and Canada. Products must be purchased in the country where service is requested. Warranty labor shall be performed by an authorized Viking Range Corporation service agency or representative. Warranty shall not apply to damage resulting from abuse, accident, natural disaster, loss of electrical power to the product for any reason, alteration, outdoor use, improper installation, improper operation, or repair or service of the product by anyone other than an authorized Viking Range Corporation service agency or representative. This warranty does not apply to commercial usage. Warrantor is not responsible for consequential or incidental damage whether arising out of breach of warranty, breach of contract, or otherwise. Some jurisdictions do not allow the exclusion or limitation of incidental or consequential damages, so the above limitation or exclusion may not apply to you.

Owner shall be responsible for proper installation, providing normal care and maintenance, providing proof of purchase upon request, and making the appliance reasonably accessible for service. If the product or one of its component parts contains a defect or malfunction during the warranty period, after a reasonable number of attempts by the warrantor to remedy the defects or malfunctions, the owner is entitled to either a refund or replacement of the product or its component part or parts. Warrantor's liability on any claim of any kind, with respect to the goods or services covered hereunder, shall in no case exceed the price of the goods or service or part thereof which gives rise to the claim.

WARRANTY SERVICE: Under the terms of this warranty, service must be performed by a factory authorized Viking Range Corporation service agent or representative. Service will be provided during normal business hours, and labor performed at overtime or premium rates shall not be covered by this warranty. To obtain warranty service, contact the dealer from whom the product was purchased, an authorized Viking Range Corporation service agent, or Viking Range Corporation. Provide model and serial number and date of original purchase. For the name of your nearest authorized Viking Range Corporation service agency, call the dealer from whom the product was purchased or Viking Range Corporation. **IMPORTANT:** Retain proof of original purchase to establish warranty period.

The return of the Owner Registration Card is not a condition of warranty coverage. You should, however, return the Owner Registration Card so that Viking Range Corporation can contact you should any question of safety arise which could affect you.

Any implied warranties of merchantability and fitness applicable to the above described surface burner are limited in duration to the period of coverage of the applicable express written limited warranties set forth above. Some jurisdictions do not allow limitations on how long an implied warranty lasts, so the above limitation may not apply to you. This warranty gives you specific legal rights, and you may also have other rights which may vary from jurisdiction to jurisdiction.

VIKING RANGE CORPORATION
111 Front Street • Greenwood, Mississippi (MS) 38930 USA • (662) 455-1200

Viking Range Corporation use & care manual

built-in gas cooktop

Specifications subject to change without notice
For more product information, call 1-888-VIKING1 (845-4641), or visit our web
site at <http://www.vikingrange.com>

Congratulations . . .

Your purchase of this product attests to the importance you place upon the quality and performance of the major appliances you use. With minimal care, as outlined in this guide, this product is designed to provide you with years of dependable service. Please take the few minutes necessary to learn the proper and efficient use and care of this quality product.

We appreciate your choosing a Viking Range Corporation product, and hope that you will again select our products for your other major appliance needs.

Table of Contents

Warnings	2
Important Safety Instructions	3
Before Using Your Cooktop	5
Using Your Cooktop	6
Cleaning and Maintenance	8
Service Information	10
Warranty	Rear Cover

WARNING

1. Read all instructions before using the product.
2. Install or locate the product only in accordance with the provided Installation Instructions.

WARNING

If the information in this manual is not followed exactly, a fire or explosion may result causing property damage, personal injury or death.

- Do not store or use gasoline or other flammable vapors and liquids in the vicinity of this or any other appliance.

WHAT TO DO IF YOU SMELL GAS

- Do not try to light any appliance
- Do not touch any electrical switch; do not use any phone in your building.
- Immediately call your gas supplier from a neighbor's phone. Follow the gas supplier's instructions.
- If you cannot reach your gas supplier, call the fire department.
- Installation and service must be performed by a qualified installer, service agency, or the gas supplier.

Important Safety Instructions

WARNING

To reduce the risk of fire, electrical shock, injury to persons, or damage when using the cooktop, follow basic precautions, including the following:

1. Your unit should be installed by a qualified technician. The appliance must be installed and electrically grounded according to national or local codes. Have this technician show the the location of the gas shut-off valve on the appliance so you know where and how to turn off the gas if necessary.
2. Do not attempt to repair or replace an part of this appliance unless specifically recommended in this manual. All servicing should be referred to a qualified technician. A qualified technician is required for any adjustments or conversions to Nat. or LP gas.
3. Do not operate the cooktop if it is not working properly, or if it has been damaged or dropped.

4. The "push-to-turn" knobs of this appliance are designed to be child-safe. However, children should not be left alone in the kitchen while the appliance is in use. Do not store items of interest to children over the unit. **CAUTION:** Children climbing to reach items could be seriously injured.
5. GREASE is flammable and should be handled carefully. Do not use water on grease fires. Never pick up a flaming pan. Smother flaming pan by covering utensil completely with well-fitting lid, cookie sheet or flat tray. Do not use water on grease fires. Flaming grease outside of utensil can be extinguished with baking soda or, if available, a multipurpose dry chemical or foam type extinguisher.
6. Wear proper apparel. Loose-fitting or hanging garments should never be worn while using the appliance.
7. Never use your cooktop for warming or heating a room. Persons could be burned or injured, or a fire could start. This is based on safety considerations.
8. Use dry pot holders. Moist or damp pot holders on hot surfaces may result in burns from steam. Do not use a towel or other bulky cloth.
9. Never leave surface area unattended at high heat setting. Boilovers cause smoking and greasy spillovers which may ignite.
10. If you are "flaming" liquor or other spirits under an exhaust hood, **TURN THE FAN OFF.** The draft could cause the flames to spread out of control.
11. Use proper pan size. Select utensils having flat bottoms large enough to cover the burner. Using undersized utensils allows the flame to come up the side of the utensil, scorching the outside of the utensil and making cleanup harder. Do not use decorative covers or trivets over the burners.
12. The flame of the surface burner should be adjusted to just cover the bottom of the pan or pot. Excessive burner setting may cause scorching of adjacent countertop surfaces, as well as the outside of the utensil. This is based on safety considerations.
13. Keep area clean and free from combustible material, gasoline, and other flammable liquids.
14. Do not heat unopened food containers; buildup of pressure may cause the container to explode. The hot contents could cause burns and container particles could cause injury.
15. To reduce the risk of burns, ignition of flammable materials, and spillage due to unintentional contact with the utensil, the handle of the utensil should be positioned so that it is turned inward toward the center of the appliance, and so that it does not extend over adjacent burners. This will help reduce the chance of burns, igniting of flammable materials, and spills due to bumping of pans.
16. Surface areas near burners may become hot enough to cause burns. During and after use, do not touch areas near burners until they have had sufficient time to cool.

17. Clean cooktop with care. Some cleaners can produce noxious fumes if applied to a hot surface. If a wet, paper towel is used to wipe spills on a hot cooking area, be careful to avoid steam burns.
18. Storage cabinet areas above the appliance must be a minimum of 36" (91.4 cm) above the appliance and cannot project more than 13" (33.0 cm) outward from the rear wall. Beware of potential hazards associated with retrieving items from such cabinets when the appliance is in operation.
19. Once the unit is installed as outlined in the Installation Instructions, it is important that the fresh air supply is not obstructed. The use of a gas cooking appliance results in the production of heat and moisture in the room in which it is installed. Ensure that the kitchen is well-ventilated. Keep natural venting holes open or install a mechanical ventilation device. Prolonged or intensive use of the appliance may call for additional (such as opening a window) or more effective ventilation (such as increasing the level of a mechanical ventilation if present).
20. Disconnect electrical supply before servicing the cooktop.

-SAVE THESE INSTRUCTIONS-

Before Using Your Cooktop

All products are wiped clean with solvents at the factory to remove any visible signs of dirt, oil, and grease which may have remained from the manufacturing process. Before starting to cook, clean the cooktop thoroughly with hot, soapy water.

Installing the Grates

When installing the grates, the sides with the ribs must always be to the outside for proper fit. The VGSU161 (36" model) has six spider grates. The VGSU101 (30" model) has four spider grates and one center grate.

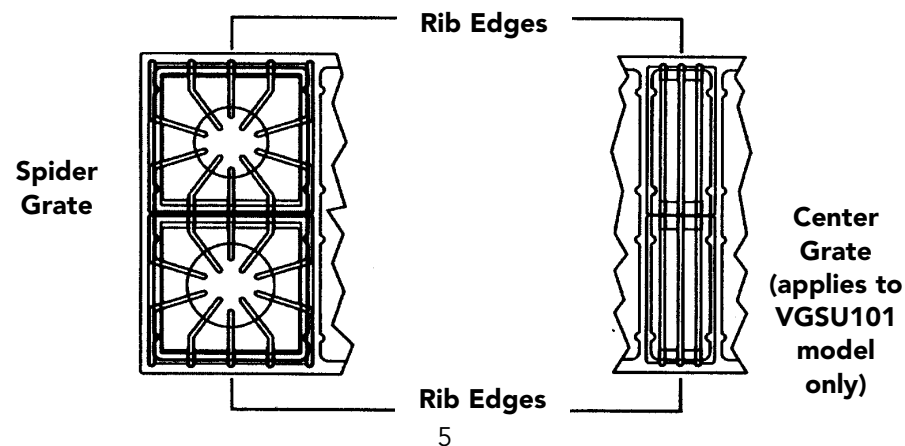

Cooking Utensils

Each cook has their own preference for the particular cooking utensils that are most appropriate for the type cooking being done. Any and all cooktop safe cooking utensils are suitable for use on the appliance, making it unnecessary to replace your present domestic utensils with commercial cookware. This is a matter of personal choice. As with any cookware, yours should be in good condition and free from excessive dents on the bottom to provide maximum performance and convenience.

NOTE: When using big pots and/or high flames, it is recommended to use the front burners. There is more room in the front and potential cleanup of rear of appliance due to staining or discoloration will be minimized.

Using Your Cooktop

Your new cooktop has sealed gas burners with an automatic reignition system. The sealed burners provide even heat distribution across the bottom of the cooking utensil.

To light the surface burners, push and turn the appropriate control knob counter-clockwise to any indicated position. This control is both a gas valve and electric switch. Burners will ignite at any "on" position with the automatic reignition system. If the flame goes out for any reason, the burners will automatically reignite if the gas is still flowing. When the gas is permitted to flow to the burners, the electric igniters start sparking. On all surface igniters you should hear a "clicking" sound. If you do not, turn off the control and check that the unit is plugged in and that the fuse or circuit breaker is not blown or tripped.

Within a few moments, enough gas will have traveled to the burner to be able to light. When the burner lights, turn the control to any position to adjust the flame. The control knobs do not have fixed positions between Hi and Simmer. They can be turned to any setting indicated or to any position in between as long as it is past the ignition position. The ignitor will turn off and the clicking will stop when the burner ignites. If the unit is not properly grounded, the ignitor will become grounded and click intermittently even after the burner has ignited. If this occurs, have a qualified technician check the wall receptacle and wiring.

IMPORTANT: The ignitors may click a number of times before the burner ignites. This is normal. All ignitors will spark regardless of which burner is being operated.

Surface Cooking Tips

- Use low or medium flame heights when cooking in utensils that are poor conductors of heat, such as glass, ceramic, and cast iron. Reduce the flame height until it covers approximately 1/3 of the utensil diameter. This will ensure more even heating within the utensil and reduce the likelihood of burning or scorching of food.
- Reduce the flame if it is extended beyond the bottom of the utensil. A flame that extends along the sides of the utensil is potentially dangerous, heats the utensil handle and kitchen instead of the food, and wastes energy.
- Reduce the flame height to the minimum level necessary to perform the desired cooking process. Remember that food cooks just as quickly at a gentle boil as it does at a rolling boil. Maintaining a higher boil than is necessary causes a loss in food flavor and nutrients.

TEMPERATURE SETTING GUIDELINES*

<u>HEAT SETTING</u>	<u>USE</u>
Simmer	Melting small quantities. Steaming rice.
Low - Simmer	Simmering small quantities, sauces.
Low	Melting large quantities.
Med - Low	Low temperature frying (eggs, etc.). Simmering large quantities. Heating milk, cream sauces, gravies.
Med	Sauteing and browning. Maintaining slow boil on large quantities.
Hi - Med	High temperature frying. Pan broiling. Maintaining fast boil on large quantities.
Hi	Boiling liquids quickly. Deep fat frying in large utensil.

***Note: The above information is given as a guide only. You may need to vary the heat settings to suit your personal requirements.**

Cleaning and Maintenance

Any piece of equipment works better and lasts longer when maintained properly and kept clean. Cooking equipment is no exception. Your appliance must be kept clean and maintained properly.

Surface Burner Grates

Make sure all surface burners are off and the surrounding parts are cool. Lift off the burner grates. Wash the grates with warm, soapy water. Use non-abrasive plastic scrubbing pad for heavily-soiled areas. Rinse and dry well. For best cleaning and to avoid possible rusting of unfinished surfaces, do not clean in a dishwasher. Replace the burner grates after cleaning.

Surface Burner Caps

The burner caps should be routinely removed and cleaned. Always clean the burner caps after a spillover. Keeping the burner caps clean will prevent improper ignition and an uneven flame.

To clean, pull the burner cap straight up from the burner base. Wipe off surface burner caps with warm, soapy water and a soft cloth after each use. Use a plastic scrubbing pad for cooked-on foods. For best cleaning and to avoid possible rusting of unfinished surfaces, do not clean in dishwasher. If ports are clogged, clean with a straight pin. **Do not enlarge or distort the ports.** Do not use a toothpick to clean the ports since they will have a tendency to break. When replacing burner caps, carefully align the tab underneath the cap with the slot in the burner.

Aluminum Base

The aluminum base should be wiped regularly with hot soapy water at the end of each cooling period. **Do not use** steel wool, abrasive cloths, cleanser, or powders. To remove encrusted materials, soak the area with a hot towel to loosen the material, then use a wooden or nylon spatula. **Do not use** a metal knife, spatula, or any other material tool to scrape the aluminum base.

Control Knobs

Turn control knobs to the OFF position. Pull the control knobs up to remove. Wash in warm water and rinse well. Do not soak. Dry completely and replace by pushing them firmly into place.

IMPORTANT: After replacing, make sure all the control knobs are in the OFF position.

Stainless Steel Parts

All stainless steel parts should be wiped regularly with hot soapy water at the end of the cooling period and with a liquid cleaner designed for stainless steel. **Do not use** steel wool, abrasive cloths, abrasive cleanser or powders. If it is necessary to scrape stainless steel to remove encrusted material, soak the area with hot towels to loosen the material, then use a wooden or nylon spatula or scraper. **Do not use** a metal knife, spatula, or any other metal tool to scrape stainless steel.

Do not permit citrus or tomato juice to remain on stainless steel surface, as citric acid will permanently discolor stainless steel. Wipe up any spills immediately.

Control Panel

DO NOT USE any cleaners containing ammonia or abrasives. They could remove the graphics from the control panel. Use hot, soapy water and a soft clean cloth.

Porcelain Parts

Wash with warm soapy water. **Do not use** steel wool, abrasive cleansers, ammonia, or acids which may damage the finish.

Power Failure

Since electronic ignition is used, electrical power failure will affect the cooktop. The electric igniters will not work. The cooktop surface burners can still be used, but only when the burners are lit manually with a match,

Service Information

If your cooktop should fail to operate:

1. Is the electrical cord securely inserted in the electrical outlet?
2. Is the circuit breaker open, or is the fuse blown?
3. Is there a gas supply to the cooktop?

If service is required:

1. Call your dealer or authorized service agency. The name of the authorized service agency can be obtained from the dealer or distributor in your area.
2. Have the following information readily available:
 - a. Model Number
 - b. Serial Number
 - c. Date of Purchase
 - d. Name of dealer from whom purchased
3. Clearly describe the problem that you are having.

If you are unable to obtain the name of an authorized service agency, or if you continue to have service problems, contact Viking Range Corporation at (662) 451-4133 or write to:

VIKING RANGE CORPORATION
PREFERRED SERVICE
111 Front Street
Greenwood, Mississippi (MS) 38930 USA

Record the following information indicated below. You will need it if service is ever required. The serial number and model number for your cooktop is located on the exterior bottom panel of the burner box in the right rear corner.

Model Number _____ Serial Number _____

Date of Purchase _____ Date Installed _____

Dealer's Name _____

Address _____

If service requires installation of parts, use only authorized parts to ensure protection under the warranty.

PLEASE RETAIN THE MANUAL FOR FUTURE REFERENCE